



Designation: E2933 – 21

Standard Specification for Stationary Point Chemical Vapor Detectors (SPCVD) for Homeland Security Applications¹

This standard is issued under the fixed designation E2933; the number immediately following the designation indicates the year of original adoption or, in the case of revision, the year of last revision. A number in parentheses indicates the year of last reapproval. A superscript epsilon (ϵ) indicates an editorial change since the last revision or reapproval.

1. Scope

1.1 General:

1.1.1 This specification presents baseline performance requirements and additional optional capabilities for stationary point chemical vapor detectors (SPCVD) designed for continuous, 24 h a day 7 days a week, monitoring of public, non-industrial facilities. This specification is one of several that describe chemical vapor detectors (for example, handheld and stationary) and chemical detection capabilities including: chemical vapor hazard detection, identification, classification, and quantification. An SPCVD is capable of detecting and alarming when exposed to chemical vapors that pose a risk as defined by the Acute Exposure Guideline Levels for Selected Airborne Chemicals (AEGL). For example, chemical vapors of interest for homeland security applications, see [Appendix X1](#). The SPCVD should not alarm to background chemical vapors and should provide low false positive alarm rates and no false negatives. Procurement agents and end users must identify the specific chemicals of interest and environmental requirements for the given facility.

1.1.1.1 An SPCVD samples air from immediate surroundings and is comprised of one or more detectors using one or more chemical detection technologies. An SPCVD also includes air sampling system(s), power system(s), computer(s), data storage, data network communication interface(s), and an enclosure, see [Fig. 1](#). An SPCVD may be combined with other SPCVDs, other chemical, biological, radiological, nuclear, and explosive (CBRNE) detectors, and other monitoring devices such as video. A remote command center may monitor and control these devices and communicate information to the responsible authorities and responders, as depicted in [Fig. 2](#).

1.1.2 This specification provides the SPCVD baseline requirements, including performance, system, environmental, and documentation requirements. This specification provides SPCVD designers, manufacturers, integrators, procurement

personnel, end users/practitioners, and responsible authorities a common set of parameters to match capabilities and user needs.

1.1.3 This specification is not meant to provide for all uses. Manufacturers, purchasers, and end users will need to determine specific requirements based on the installation location and environment.

1.2 *SPCVD Chemical Detection Capabilities*—Manufacturers document and verify, through testing, the chemical detection capabilities of the SPCVD. Test methods for assessing chemical detection capabilities are available from the Department of Homeland Security and the Department of Defense and are listed in [Appendix X2](#).

1.3 *SPCVD System and Environmental Properties*—Manufacturers document and verify, through testing, the system and environmental properties of the SPCVD. Example test methods for assessing the system and environmental properties are listed in [Appendix X3](#).

1.4 *Units*—The values stated in SI units are to be regarded as standard. Vapor concentrations of the hazardous materials are presented in parts per million (ppm) as used in Acute Exposure Guideline Levels for Selected Airborne Chemicals, Vols 1-9 (see [2.2](#)) and in mg/m^3 .

1.5 *This standard does not purport to address all of the safety concerns, if any, associated with its use. It is the responsibility of the user of this standard to establish appropriate safety, health, and environmental practices and determine the applicability of regulatory limitations prior to use.*

1.6 *This international standard was developed in accordance with internationally recognized principles on standardization established in the Decision on Principles for the Development of International Standards, Guides and Recommendations issued by the World Trade Organization Technical Barriers to Trade (TBT) Committee.*

¹ This specification is under the jurisdiction of ASTM Committee E54 on Homeland Security Applications and is the direct responsibility of Subcommittee E54.01 on CBRNE Detection and Decontamination.

Current edition approved Sept. 1, 2021. Published September 2021. Originally approved in 2013. Last previous edition approved in 2013 as E2933 – 13. DOI: 10.1520/E2933-21.

CFR Title 47 Telecommunication, Part 15 Radio Frequency Devices, and Part 18 Industrial, Scientific, and Medical Equipment.

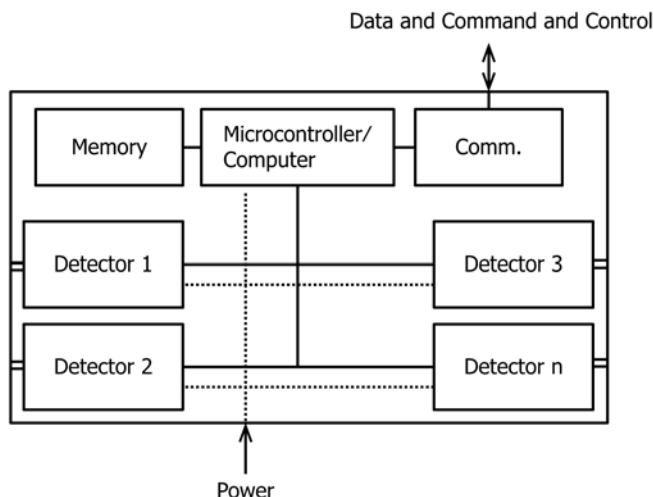

The SPCVD is a unit which samples air from immediate surroundings and is comprised of one or more detectors using one or more chemical detection technologies. An SPCVD also includes air sampling system(s), power system(s), computer(s), data storage, data network communication interface(s), and an enclosure.

FIG. 1 An Example Schematic of a Stationary Point Chemical Vapor Detector (SPCVD)

2. Referenced Documents

2.1 ASTM Standards:²

E2885 Specification for Handheld Point Chemical Vapor Detectors (HPCVD) for Homeland Security Applications

2.2 U.S. Environmental Protection Agency:³

Acute Exposure Guideline Levels for Selected Airborne Chemicals, Vols 1–9.

2.3 U.S. Department of Homeland Security:⁴

Chemical Detection Performance Specifications for Mass Transit and Passenger Rail Systems

National Information Exchange Model (NIEM), <http://www.niem.gov/>.

2.4 National Institute of Standards and Technology (NIST):⁵

Publication 140–2 Security Requirements for Cryptographic Modules

2.5 Code of Federal Regulations:⁶

CFR, Title 40 Protection of the Environment, Part 72.2 Permits Regulation, Definitions.

CFR, Title 10 NRC Regulations, Part 30.20, Gas and Aerosol Detectors Containing Byproduct Material

² For referenced ASTM standards, visit the ASTM website, www.astm.org, or contact ASTM Customer Service at service@astm.org. For *Annual Book of ASTM Standards* volume information, refer to the standard's Document Summary page on the ASTM website.

³ Committee on Acute Exposure Guideline Levels, Committee on Toxicology, Board on Environmental Studies and Toxicology, Division on Earth and Life Studies, National Research Council of the National Academies; 2000–2010, <http://www.epa.gov/oppt/aegl/index.htm>, updated August 2010.

⁴ Available from the Office of Health Affairs, Chemical Defense Program, and the Transportation Security Administration, 245 Murray Lane, NW, Mail Stop 0315, Washington, D.C. 20528, March 2011.

⁵ Available from National Institute of Standards and Technology (NIST), 100 Bureau Dr., Stop 1070, Gaithersburg, MD 20899-1070, <http://www.nist.gov>. May 2001.

⁶ Available from U.S. Government Printing Office Superintendent of Documents, 732 N. Capitol St., NW, Mail Stop: SDE, Washington, DC 20401, <http://www.access.gpo.gov>.

3. Terminology

3.1 Definitions:

3.1.1 *30-minute Acute Exposure Guideline Levels for Selected Airborne Chemicals (30-min AEGL value)*, *n*—represent threshold exposure limits for the general public and are applicable to emergency exposure periods for 30 minutes.

3.1.2 *AEGL-1*, *n*—airborne concentration (expressed as parts per million (ppm) or mg/m³) of a substance above which it is predicted that the general population, including susceptible individuals, could experience notable discomfort, irritation, or certain asymptomatic nonsensory effects; however, the effects are not disabling and are transient and reversible upon cessation of exposure.

3.1.3 *AEGL-2*, *n*—airborne concentration (expressed as ppm or mg/m³) of a substance above which it is predicted that the general population, including susceptible individuals, could experience irreversible or other serious, long-lasting adverse health effects or an impaired ability to escape.

3.1.4 *AEGL-3*, *n*—airborne concentration (expressed as ppm or mg/m³) of a substance above which it is predicted that the general population, including susceptible individuals, could experience life-threatening health effects or death.

3.1.5 *alarm*, *n*—sound, light, vibration, or data communication signal to the operator(s), or combinations thereof, indicating that the stationary point chemical vapor detector (SPCVD) has detected the presence of a chemical vapor(s) of interest at or above the alarm threshold value.

3.1.6 *alarm threshold value*, *n*—vapor concentration corresponding to an AEGL value (AEGL-1, AEGL-2, or AEGL-3) that activates an SPCVD alarm.

3.1.7 *background chemical vapors*, *n*—incidental chemical vapors present in the environment at vapor concentrations lower than the 30-minute AEGL-1 values.

3.1.8 *consumables*, *n*—SPCVD components that require periodic replacement.

3.1.9 *enclosure*, *n*—an integral part of the SPCVD that protects the internal SPCVD components from harm including effects from temperature, moisture, dust, mechanical stress, and tampering.

3.1.10 *facility*, *n*—area, structure, or surroundings, or combinations thereof, to be monitored by the SPCVD (for example, a building, parking lot, transportation station, and airport).

3.1.11 *false negative*, *n*—the SPCVD fails to alarm in the presence of a chemical of interest when the vapor concentration is at or above the indicated alarm threshold value.

3.1.12 *false positive alarm*, *n*—the SPCVD indicates the presence of a chemical of interest when none is present or if the chemical is present at vapor concentrations less than 50 % of the indicated alarm threshold value.

3.1.13 *identify*, *v*—indicate actual chemical detected by the SPCVD.

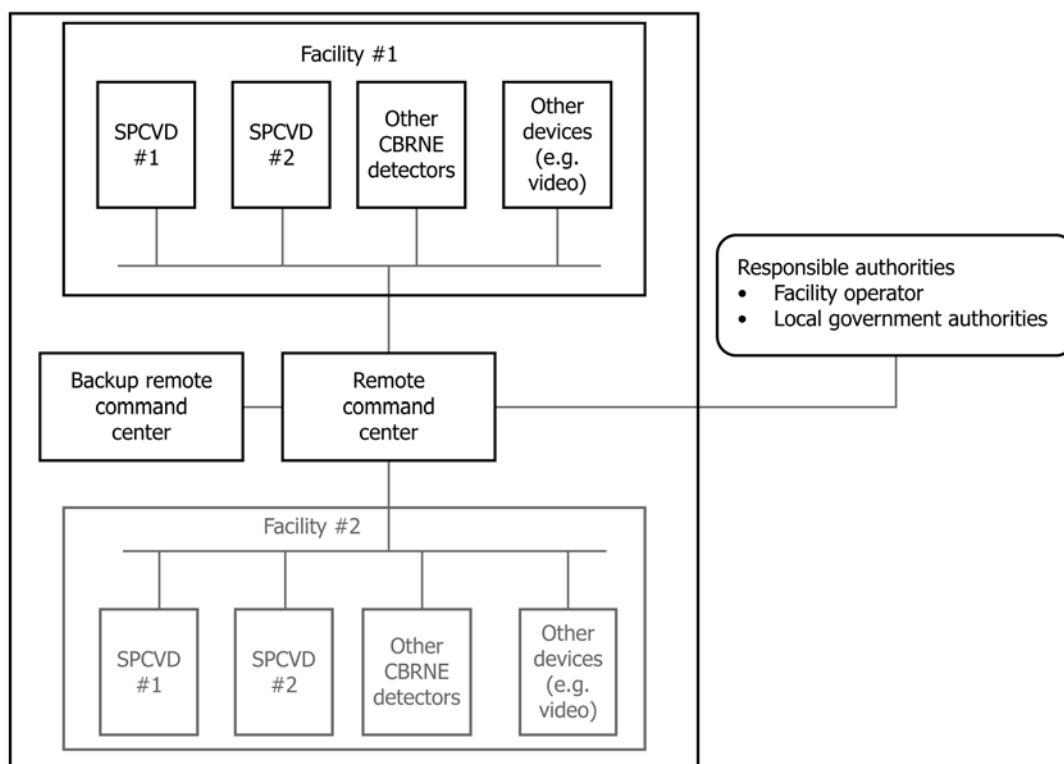

FIG. 2 A Conceptual Representation of a Facility Security System with Stationary Point Chemical Vapor Detectors (SPCVDs) integrated with other Chemical, Biological, Radiological, Nuclear, and Explosive (CBRNE) Detectors, and Other Monitoring Devices such as Video

3.1.14 *indicator, n*—information other than an alarm provided to the operator(s) by the SPCVD.

3.1.15 *laboratory challenge stream, n*—a synthesized chemical vapor mixture used in the laboratory to verify the chemical detection capabilities of an SPCVD.

3.1.16 *local operations, n*—control and monitoring of the SPCVD at or near the physical location of the SPCVD.

3.1.17 *mean time between failures, n*—estimate of the elapsed time between inherent failures of a system during operation, one measure of system reliability.

3.1.18 *probability of detection, n*—under specific conditions, the probability that the SPCVD will activate an alarm when a chemical of interest is present at or above the alarm threshold values.

3.1.19 *remote command center, n*—a location where an operator remotely controls and monitors SPCVD(s), other CBRNE detectors, and other monitoring devices; the remote command center communicates information to the responsible authorities, see Fig. 2.

3.1.20 *remote operations, n*—control and monitoring of the SPCVD from a remote command center.

3.1.21 *response time, n*—time required for the SPCVD to detect and activate an alarm when exposed to a chemical of interest at vapor concentrations at or above the alarm threshold value.

3.1.22 *saturation, n*—a condition in which the detector response no longer increases with increased vapor concentration.

3.1.23 *selectivity, n*—ability of an SPCVD to distinguish one or more chemicals of interest in the presence of background chemical vapors.

3.1.24 *sensitivity, n*—ability to detect one or more chemicals of interest at the alarm threshold values within the specified response time.

3.1.25 *stationary point chemical vapor detector (SPCVD), n*—a unit which samples air from immediate surroundings and is comprised of one or more detectors using one or more chemical detection technologies; an SPCVD also includes air sampling system(s), power system(s), computer(s), data storage, data network communication interface(s), and an enclosure, see Fig. 1; an SPCVD may be integrated into a larger monitoring system, as depicted in Fig. 2.

3.1.26 *vapor, n*—in the context of this specification, vapor refers to either gases or gas phase chemicals where the same substance may also exist in either a liquid or solid state.

4. Chemical Detection Performance Requirements

4.1 The manufacturer shall document the baseline and additional optional capabilities of the SPCVD to detect, identify, and quantify the chemical vapor hazards.

4.2 Detection and Hazard Identification:

4.2.1 The baseline capability of the SPCVD is to detect and alarm to one or more hazardous chemical vapors listed in the Acute Exposure Guideline Levels for Selected Airborne Chemicals. Tables X1.1 and X1.2 in Appendix X1 provide a representative list of chemical vapor hazards.